

SCHMEISER[®] VARITRAK LAND LEVELER

ASSEMBLY & PARTS MANUAL



16, 20, & 24 FT. WIDE

T. G. SCHMEISER CO., INC.

P.O. BOX 1047 FRESNO, CA 93714-1047

(559) 268-8128 FAX (559) 268-3279

www.tgschmeiser.com

**VERSION 1.2
03-2011**

INTRODUCTION

Your Schmeiser Varitrak Leveler is designed to give you many years of dependable service. This manual has been prepared to instruct you in the safe and efficient operation of this machine. Read and study it thoroughly. Follow all instructions carefully.

Should your Varitrak Leveler require replacement parts, go to your Schmeiser dealer. Always order genuine Schmeiser replacement parts.

It is important that you complete and send in your Warranty Card because it is not valid unless it is on file at Schmeiser. If you need information not contained in this manual, contact your Schmeiser dealer.

Space has been provided below for you to record the model number and serial number of your Varitrak Leveler. Be sure to bring this information with you to your dealer when ordering parts or attachments for your Varitrak Leveler.

Thank you for buying a Schmeiser Varitrak Leveler.

SERIAL NUMBER _____

MODEL NUMBER _____

DATE PURCHASED _____

DEALER NAME _____

TABLE OF CONTENTS

Introduction.....	2
Table of Contents.....	3
Safety Sheet	4
Varitrak Specifications Sheet.....	5
Varitrak Leveler Assembly Instructions	6
Varitrak Leveler Operating Instructions	8
Varitrak Specification	9
Varitrak Leveler Assembly	10
Varitrak Front Self-Leveling 3-Pt. Hitch Assembly	12
Varitrak Front Laser Option 3-Pt. Hitch Assembly	13
Varitrak Wing Linkage and Turnbuckle Assembly	14
Varitrak Sliding Plates Assembly	15
Varitrak Rear Rubber Wheel Frame Assembly	16
Varitrak Rear Steel Wheel Frame Assembly	17
Varitrak Wing Assembly	18
Varitrak Rear Braces Assembly.....	19
Varitrak S-Tine Attachment Assembly (Optional).....	20
Varitrak Hydraulic Diagrams.....	21
Limited Warranty.....	23
Varitrak Maintenance and Repair Record.....	24

SAFETY

The safe operation of any machinery is an important concern to farmers and manufactures. There are obvious and hidden potential hazards involved in the operation of this implement. Carefully read and follow all safety precautions before operation. Serious injury or death may occur unless care is taken to insure the safety of both the operator and any other persons in the area.

1. This is a rear-mounted implement that removes weight from the front wheels of the tractor and can cause loss of steering with possible overturn. Add front-end weight until at least 20% of tractor original weight is on the front wheels when leveler is in transport position for steering and prevention of bodily injury. When on rough surfaces, transport slowly to prevent bouncing front wheels off surface with loss of steering and possible injury.
2. Be especially careful when transporting on slopes. Never turn uphill in transport except at slow speed and a low rate of turn. Never transport or operate this machine on steep slopes.
3. Never permit anyone to ride on or walk beside the implement when moving.
4. Never permit anyone to ride on tractor when implement is being moved.
5. Never allow anyone to be near the implement when performing operating functions with implement or tractor.
6. Do not enter tractor when tractor is moving. Avoid serious injury or death from contact with rotating tires. Enter and exit the tractor only when it is completely stopped.
8. When in transport, use accessory lights and devices for adequate warning to operators of other vehicles. Comply with all Federal, State and local laws when traveling on public roads.
9. Use "Slow Moving Vehicle" emblem for warning vehicles approaching from the rear.
10. When transporting, remember that the implement may be wider than your tractor and extreme care must be taken to allow for safe clearance.
11. Never allow inexperienced or untrained personnel to operate the implement or tractor without supervision.
12. When using compressed air to clean implement, wear safety glasses.
13. Check all fasteners for tightness or damage before and after operation. Repair immediately if required.
14. Store implement in a stable position.



NOTE: Leave all bolts loose until indicated!

1. Select a smooth, level area approximately 26 feet wide and 26 feet long.
2. Position main frame on the ground and centered in the area with the open bucket facing the direction that the machine is to be pulled
3. Position and attach slide tube to the main frame with (4) 3/4" x 2-1/2" NC Cap Screws and (4) 5/8" x 2" NC Cap Screws with lock washers and hex nuts.
4. Install slide plates assembly on slide tube. Refer to page 15 drawing for proper installation.
Note: Make sure slide plates and slide roller holes align before installing. Do not attempt to force pins through slide rollers.
5. Attach rod end of 3" x 36" Hydraulic Cylinder to the slide plate cylinder anchor using 1" cylinder pin and hair pin clips. Attach other end to the main frame cylinder anchor using 1" cylinder pin and hair pin clips.
6. Hoist and attach left wing and right wing with wing hinge pins, slotted nuts, and cotter pins. See page 18 for reference.
7. Install wing linkage assemblies. Refer to page 14 drawing for proper installation.
 - a. Install wing turnbuckle assemblies as follows:
 - attach double clevis turnbuckle end to wing end plate using 1" x 3-1/2" bolts and nylon lock hex nuts. Tighten enough to allow free movement.
 - attach single clevis turnbuckle end to wing linkage weldment with 1" x 3-1/2" bolts and nylon lock hex nuts. Tighten enough to allow free movement.
 - b. Attach rod end of 4" x 12" hydraulic cylinder to the center plate of wing linkage assembly. Attach other end to the main frame. Repeat for the other side.
 - c. Level wings. Adjust if necessary using (2) 3/4" x 2" NC bolts installed on the bottom of main frame side plates and wing linkage assemblies. Use 1" x 2-1/2" NC bolts with jam nuts on each wing lock to obtain a movement arm where the pivot point is 1/8" to 1/4" past center.
8. Hoist and attach primary brace LH and primary brace RH to the main frame using 1-1/4" x 11" pins with slotted nuts and cotter pins. Refer to page 15 for details.
9. Attach rear wheel frames with rubber tires to the main braces as shown on page 16.
10. If the optional steel wheels are ordered, attach wheel scraper arms RH and LH to rear wheel frames (forks). Attach scraper blades to scraper arms. See page 17 for details.



14. INSTALLATION PROCEDURE - SELF-LEVELING HITCH.

- a. Position hitch top link in the lower of the top main frame holes. Secure with 1-1/4" x 5-1/2" shoulder bolt and 1-1/4" nylon lock hex nut making sure not to damage self-luibrating bushings. Refer to page 12 for proper installation.
- b. Position H-Frame with the bottom holes on main frame and attach with 1-1/2" x 8" pin, bushing, 3/8" x 3" bolt with lock washer and hex nut.
- c. Position A-Frame on H-Frame and fasten with two 1-1/2" x 6-1/4" pins and lock in position with 1/4" lynch pins.
- d. Position short link between top link and A-Frame and install each end (being careful not to damage self-lubrication bushings) with 1-1/4" x 3-3/4" and 1-1/4" x 4-1/2" shoulder bolts and nylon lock hex nuts.
- e. Position RH and LH long links between H-Frame and top link and secure each end with 1-1/4" x 4-1/2" shoulder bolt. Install 1-1/4" nylon lock hex nuts. Tighten enough to allow free movement.
- f. Attach self-leveling hitch to tractor's hitching points. Adjust tractor top link until hitch A-Frame is vertical.

15. Connect the four hydraulic lines to tractor lines and check for leaks.

WARNING: When transporting Varitrak, attach bucket lockout bars to wing linkage assemblies with 2-hole pins. This is to prevent the accidental lowering of the bucket wings. When lowering the buckets after transportation or storage, caution must be taken to see that the surface area is smooth and level and that the main frame blade is not cutting into the ground. Thsi will prevent the buckets from trapping soil between the side plates on buckets and main frame when they are lowered into position. Any build up of soil could severely damage turnbuckles, wing locks and /or hydraulic system.

NOTE: Go back over the entire leveler to check and securely tighten all nuts and bolts. Before starting operation, grease all grease fittings with good quality grease.

16. INSTALLATION PROCEDURE - LASER CONTROL KIT.

- a. Remove the top link, short link, and long link from the self-leveling hitch.
- b. Install the cylinder attaching anchor in the two upper holes of the main frame, use 1-1/4" x 5-1/2" NC bolts with lock washers and hex nuts.
- c. Connect the front hydraulic cylinder barrel end to the cylinder attaching anchor and the rod end on hydraulic cylinder to the hole on the H-Frame with the cylinder ports facing to the right. See page 13 for details.
- d. Attach the laser stand to the main frame. The slotted holes are for leveling the top of the laser stand.
- e. Check the complete hydraulic system for leaks under pressure and complete the assembly of laser control components. After testing, install all shields and covers.



1. Adjust the bucket blade height with the tractor's 3-point hitch hydraulic control. This will determine the load that will be carried in the bucket. The recommended load is to have the bucket 2/3 full in operation.
2. After the blade height has been set, adjust the center link of the tractor's 3-point hitch so the H-Frame is parallel to the ground. This is required to obtain the maximum compensation in leveling. Whenever the working height of the blade is changed, the center link should be readjusted to keep the H-Frame parallel to the ground.
3. The top link of the 3-point hitch should be adjusted so that the A-Frame of the self-leveling hitch is perpendicular to the ground. This is necessary to get the maximum compensation (travel) in leveling.
4. The width of the rear wheel tread can be adjusted while in motion but should not extend past the bucket ends. This allows wide lateral stability and land leveling and narrow tread width while turning in a corner or along a ditch or levee.
5. The bucket wings can be raised and lowered hydraulically. When in the down position, they are mechanically locked rigid for land leveling. There are holes for a bolt near the bottom and in the back of the bucket that can be used to hold the bucket wings down if the hydraulic lines are disconnected.
 - a. There is an adjusting screw near the bottom and in the back of the bucket roll on each side. This is for adjusting the bucket wings level with the center section. Always make sure that all three buckets are in line.
 - b. The large turnbuckles on each wing lock must be adjusted to hold the bucket wings down tight when in locked position. There are two adjusting screws on each lift lock that are used to adjust the hydraulic cylinder stroke to lock the hydraulic cylinder pins about 1/8" to 1/4" past center. This will hold the bucket wings in a locked position with no pressure on hydraulic lines.
6. Traversing ditches that are over three feet wide and twelve inches deep or crossing levees over twelve inches in height at a ninety-degree angle to the ditch or levee **SHOULD BE AVOIDED**. If this cannot be avoided, the top link of the tractor's 3-point hitch should be disconnected to prevent the self-leveling hitch from exceeding its travel limits and becoming damaged. It is recommended in crossing a ditch or levee that the tractor and the land leveler approach at an approximate forty-five degree angle to allow the self-leveling hitch to operate most efficiently.
7. When lowering the bucket wings, be sure that the center bucket section is clear of the ground so that dirt is not trapped between the buckets sections. Dirt will prevent the buckets from lining up and forcing the sections will damage the bucket lift mechanism.



OPERATION WITH A LASER SYSTEM

1. Level the laser stand by loosening the four cap screws and using a carpenters level on the top plate of the laser stand. Retighten when level.
2. Adjust the tractors 3-point hitch so that the tractor lift links are parallel to the ground.
3. Lengthen top link on the tractor until there is from 1-3/4" to 2" of down stroke on 3 x 8 cylinder.

CAUTION: Make sure all pivot points on the hitch fit tightly so that the laser system has no false motion for which to compensate.

WHEN TRANSPORTING THE LAND LEVELER ON THE ROAD:

When transporting the Varitrak Land Leveler with the tractor, the center link of the 3-point hitch must be disconnected; otherwise, the hitch may be damaged if the travel limits of the hitch are exceeded.

WARNING: The self-leveling hitch should be examined for damage if:

- a. The bucket goes to maximum cut and remains there.
 - b. The self leveling hitch does not appear to be compensating for ground variations.
4. The two bucket wings are equipped with safety links. They must be used when the bucket wings are in the raised position before attempting to transport. This will prevent accidental lowering of the bucket wings.



Model Number	Bucket Width	Rear Track	Weight
SVT-16R	16 Ft. (4.9 m)	min. 9.0 Ft. (2.7 m) max. 16.0 Ft. (4.9 m)	3600 Lbs. (1633 kg)
SVT-16S	16 Ft. (4.9 m)	min. 9.6 Ft. (3.0 m) max. 16.0 Ft. (4.9 m)	3920 Lbs. (1778 kg)
SVT-20R	20 Ft. (6.0 m)	min. 9.0 Ft. (2.7 m) max. 23.0 Ft. (7.0 m)	4440 Lbs. (2011 kg)
SVT-20S	20 Ft. (6.0 m)	min. 9.6 Ft. (3.0 m) max. 24.0 Ft. (7.3 m)	4760 Lbs. (2156 kg)
SVT-24R	24 Ft. (6.0 m)	min. 9.0 Ft. (2.7 m) max. 23.0 Ft. (7.0 m)	4587 Lbs. (2078 kg)
SVT-24S	24 Ft. (6.0 m)	min. 9.6 Ft. (3.0 m) max. 24.0 Ft. (7.3 m)	4907 Lbs. (2223 kg)

HORSEPOWER:

	SVT-16R	SVT-20R	SVT-24R
Minimum Drawbar	110 (82 kW)	130 (97 kW)	150 (112 kW)
Recommended Drawbar	125 (93 kW)	150 (112 kW)	180 (134 kW)

H.P. requirements for crawlers rated at 65% of above.

H.P. requirements for 4-wheel drive tractors rated at 85% of above.

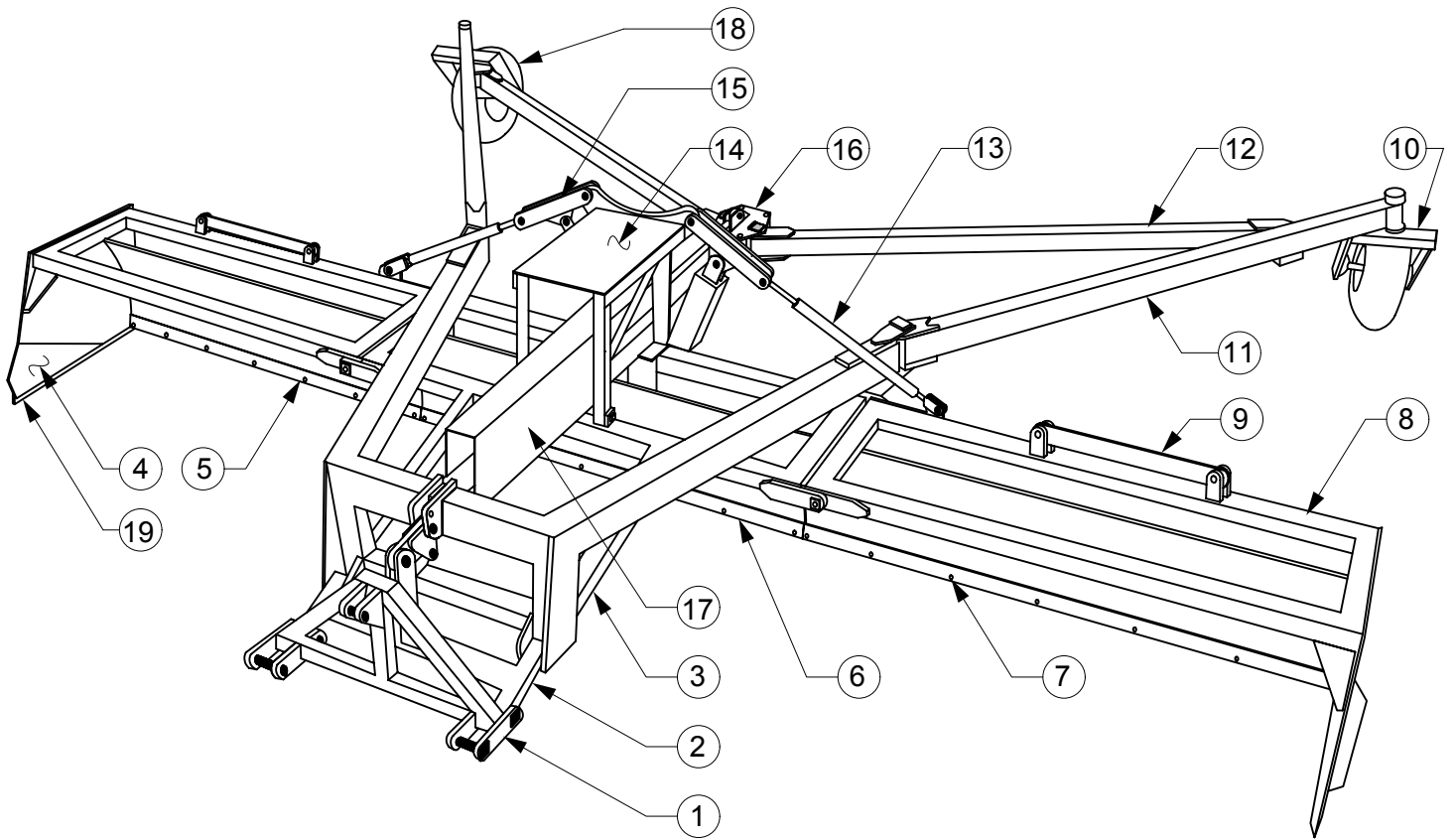



<u>Ref No.</u>	<u>Part No.</u>	<u>Description</u>	<u>Qty.</u>
1.	SVT-00A100	Varitrak Front A-Frame Weldment	1
2.	SVT-00A500	Varitrak H-Frame	1
3.	SVT-(00)B100	Varitrak Main Frame Weldment (specify width)	1
4.	SLP-00L200L(R)	Bucket Side Weldment Left and Right	2
5.	SVT-(00)B205R	Varitrak Wing Blade RH Side (specify width)	1
6.	SVT-(00)B105	Varitrak Main Frame Blade (specify width)	1
7.	SVT-(00)B205L	Varitrak Wing Blade LH Side (specify width)	1
8.	SVT-(00)D100	Varitrak Wing Weldment Pair (specify width)	1
9.	SVT-00D200	Varitrak Wing Lockout Weldment	2
10.	SVT-00G000	Varitrak Wheel Frame Weldment	2
11.	SVT-00C100	Varitrak Rear Main Brace Weldment	2
12.	SVT-00C200	Varitrak Rear Secondary Brace Weldment	2
13.	SVT-00K000	Varitrak Turnbuckle Assembly	2
14.	SVT-00B400	Varitrak Laser Mount Weldment	1
15.	SVT-00F000	Varitrak Wing Linkage Weldment	2
16.	SVT-00E100	Varitrak Top Sliding Plate Weldment	1
	SVT-00E200	Varitrak Bottom Sliding Plate Weldment	1
17.	SVT-00B122	Varitrak Hydraulic Hose Cover	1
18.	GWT-111408	11L X 14 Tire with Wheel Assembly (Std.)	2
	SLP-00D000	30" Steel Wheel Weldment (Optional)	2
19.	SLP-00L204	Bucket Side Adjustment Blade	2

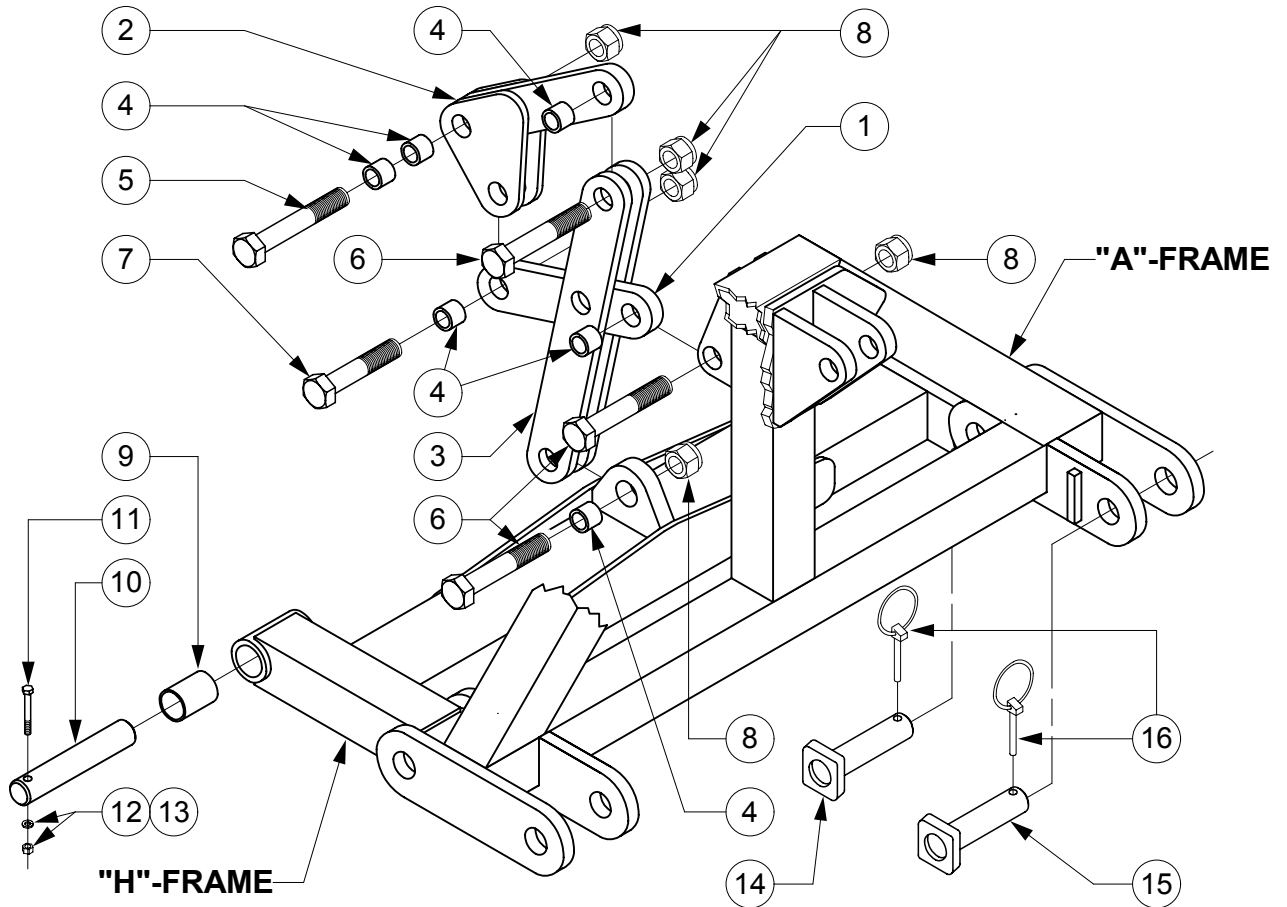

<u>Ref No.</u>	<u>Part No.</u>	<u>Description</u>	<u>Qty.</u>
1.	SVT-00A200	3-Pt. Hitch Short Link	1
2.	SVT-00A400	3-Pt. Hitch Top Link Weldment	1
3.	SVT-00A300	3-Pt. Hitch Long Link	2
4.	GBR-2024G16	1-1/4" X 1-1/2" X 1" Self-Lubricating Bushings	6
5.	SVT-00A302	1-1/4" x 5-1/2" Long Shoulder Bolt	1
6.	SVT-00A303	1-1/4" x 4-1/2" Long Shoulder Bolt	3
7.	SVT-00A304	1-1/4" x 3-3/4" Long Shoulder Bolt	1
8.	NYNUT-20NC	1-1/4" Nylon Lock Hex Nut NC	5
9.	GBR-2428G60	1-3/4" X 1-1/2" X 3-3/4" Self-Lubricating Bushings	4
10.	SVT-00A600	Varittrak Main Frame Pin	2
11.	CSNC506048	3/8" X 3" Gr. 5 Cap Screw	2
12.	HXNUT-06NC	3/8" NC Hex Nut	2
13.	LWASHER-06	3/8" Lock Washer	2
14.	SVT-00A700	Varittrak "A"-Frame to "H"-Frame Pin Weldment	2
15.	SVT-00A900	Varittrak "A"-Frame Front Pin Weldment	2
16.	GPN-040LYN	1/4" Lynch Pin	4

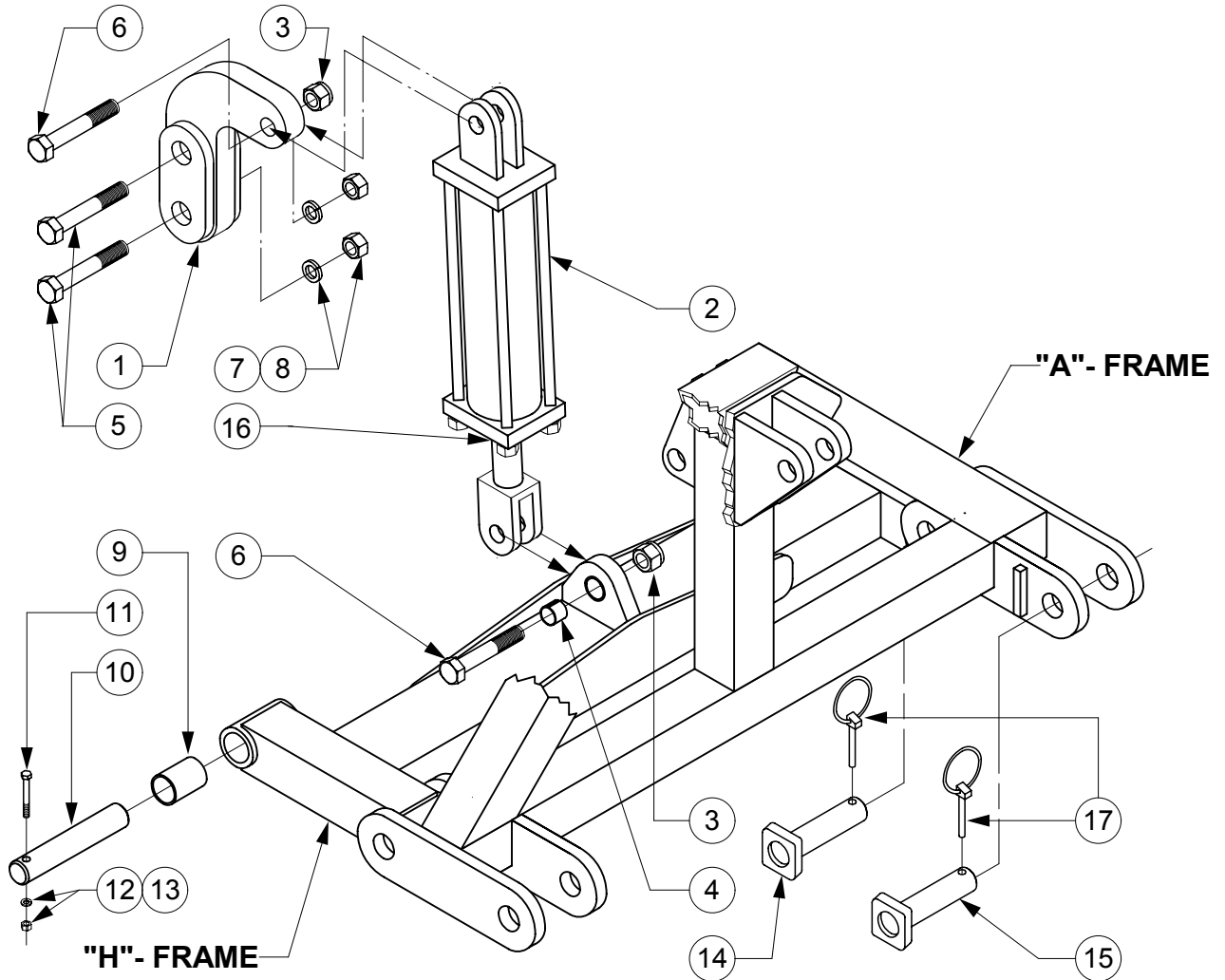

<u>Ref No.</u>	<u>Part No.</u>	<u>Description</u>	<u>Qty.</u>
1.	SVT-00A800	Laser Option Cylinder Anchor Weldment	1
2.	GHC-30080T	3" X 8" Tie Rod Hydraulic Cylinder	1
3.	NYNUT-20NC	1-1/4" Nylon Lock Hex Nut NC	2
4.	GBR-20X16T	1-1/4" X 1" X 1" Tension Bushing	1
5.	CSNC520088	1-1/4" x 5-1/2" Gr.5 NC Cap Screw	2
6.	SVT-00A303	1-1/4" x 4-1/2" Long Shoulder Bolt	2
7.	LWASHER-20	1-1/4" Lock Washer	2
8.	HXNUT-20NC	1-1/4" Hex Nut NC	2
9.	GBR-2428G60	1-3/4" X 1-1/2" X 3-3/4" Self-Lubricating Bushings	4
10.	SVT-00A600	Varittrak Main Frame Pin	2
11.	CSNC506048	3/8" X 3" Gr. 5 Cap Screw	2
12.	HXNUT-06NC	3/8" NC Hex Nut	2
13.	LWASHER-06	3/8" Lock Waser	2
14.	SVT-00A700	Varittrak "A"-Frame to "H"-Frame Pin Weldment	2
15.	SVT-00A900	Varittrak "A"-Frame Front Pin Weldment	2
16.	PMCK33000	Seal Kit for 3" X 8" Hydraulic Cylinder	1
17.	GPN-040LYN	1/4" Lynch Pin	4

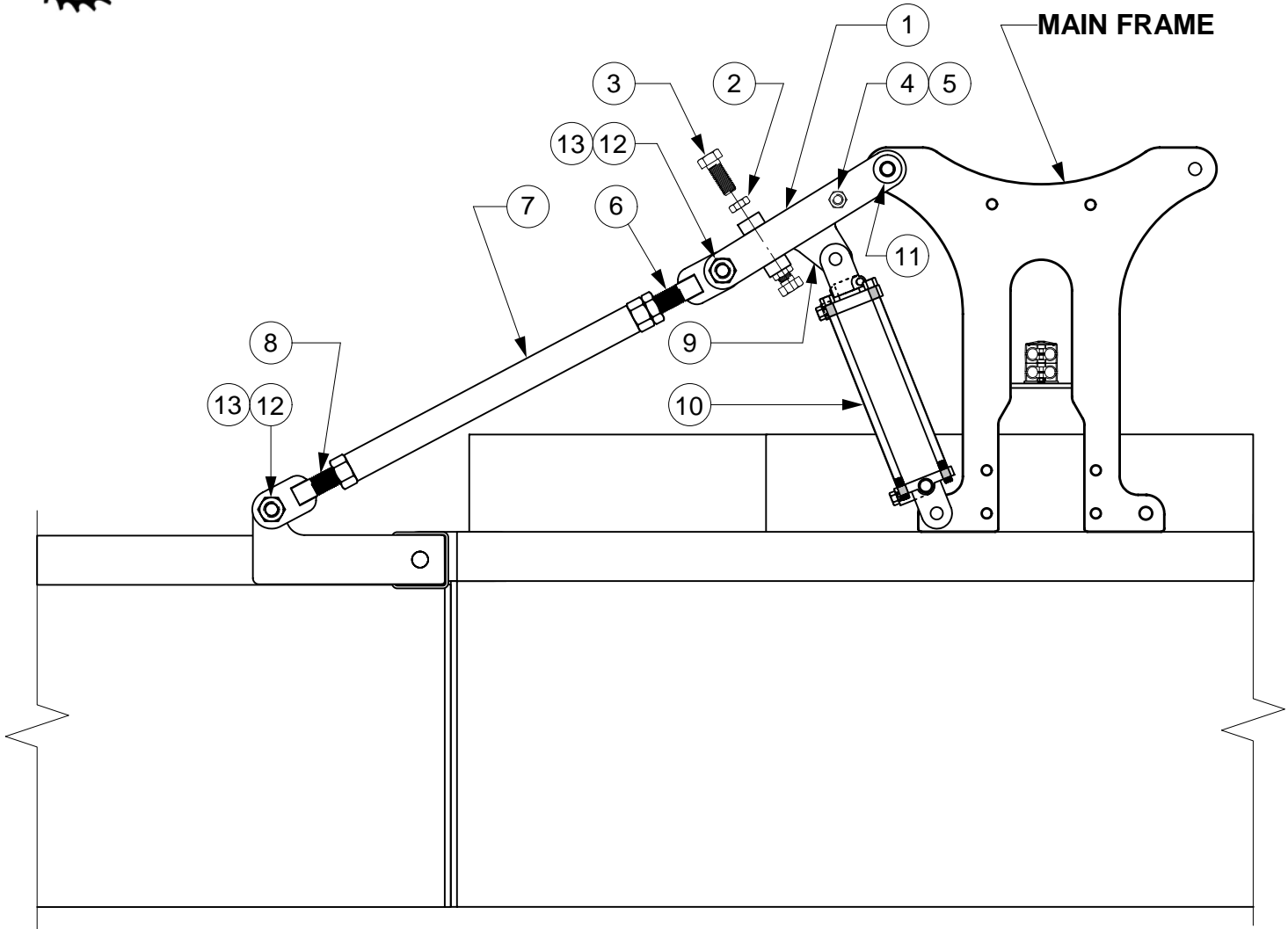

<u>Ref No.</u>	<u>Part No.</u>	<u>Description</u>	<u>Qty.</u>
1.	SVT-00F000	Wing Linkage Weldment	2
2.	HXNUTJ16NC	1" NC Hex Jam Nut	4
3.	CSNC816040	1" x 2-1/2" Gr. 8 Cap Screw	4
4.	CSNC508048	1/2" X 3" Gr. 5 Cap Screw	2
5.	NYNUT-08NC	1/2" NC Nylon Lock Hex Nut	2
6.	SVT-00K200	Turnbuckle Top RH Thread Rod Weldment	2
7.	SVT-00K100	Turnbuckle Body Weldment	2
8.	SVT-00K300	Turnbuckle Bottom LH Thread Rod Weldment	2
9.	SVT-00F001	Wing Linkage Center Plate	2
10.	GHC-40120T	4" X 12" Tie Rod Hydraulic Cylinder	2
11.	SVT-00F003	Varitrak Wing Linkage Pin Weldment	2
12.	CSNC516056	1" X 3-1/2" NC Cap Screw	4
13.	NYNUT-16NC	1" NC Nylon Lock Hex Nut	4
	SVT-F	Wing Linkage Assembly (includes items 1, 2, 3, 4, 5, 9)	
	SVT-K	Turnbuckle Assembly (includes items 6, 7, 8)	

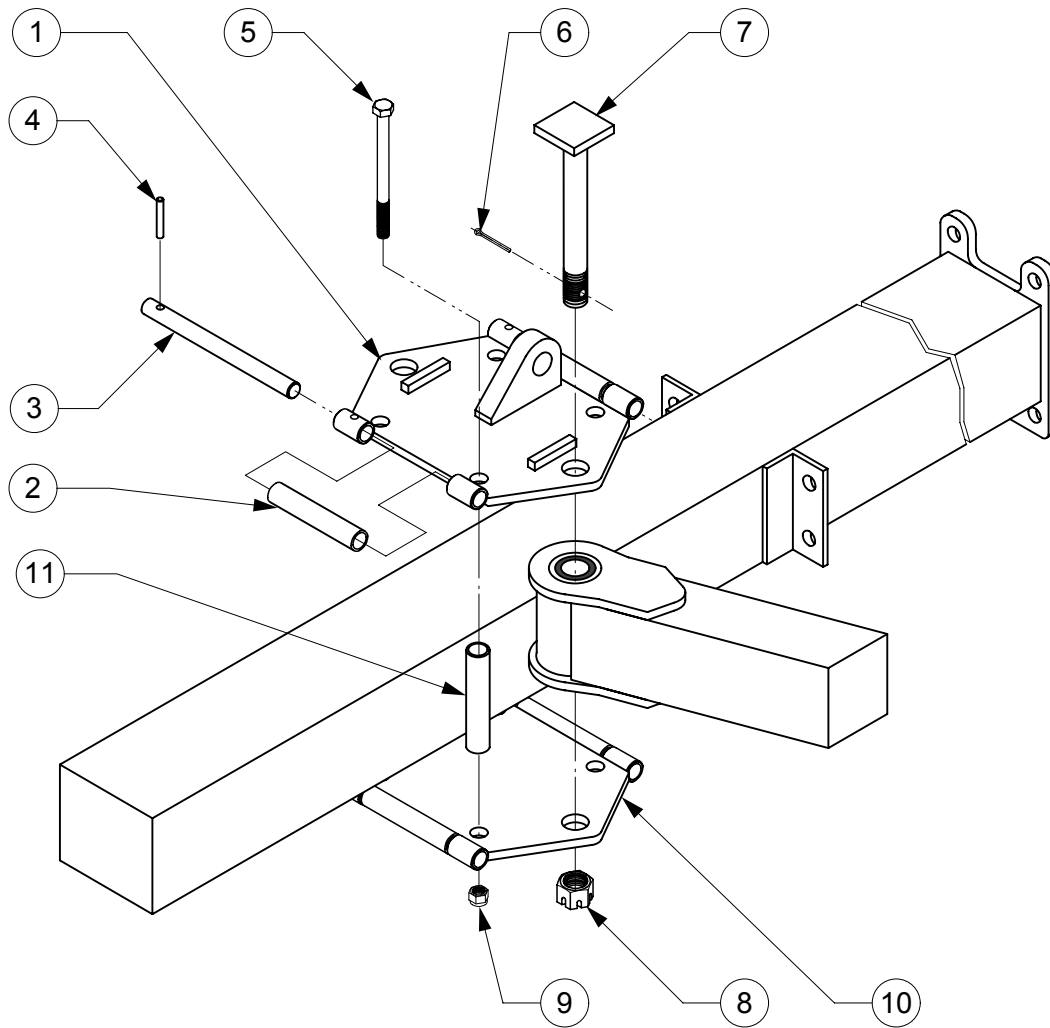

<u>Ref No.</u>	<u>Part No.</u>	<u>Description</u>	<u>Qty.</u>
1.	SVT-00E100	Top Sliding Plate Weldment	1
2.	SVT-00E300	Sliding Plate Roller	4
3.	SVT-00E400	Sliding Plate Roller Pin	4
4.	GPN-05X40R	5/16" X 2-1/2" Roll Pin	4
5.	CSNC510144	5/8" X 9" NC Cap Screw	4
6.	GPN-04X40C	1/4" X 2-1/2" Cotter Pin	2
7.	SVT-00J300	1-1/4" X 8-3/4" Brace to Sliding Plate Pin Weldment	2
8.	HXNUTS20NF	1-1/4" NF Slotted Hex Nut	2
9.	NYNUT-10NC	5/8" NC Nylon Lock Hex Nut	4
10.	SVT-00E200	Bottom Sliding Plate Weldment	1
11.	SVT-00E500	Sliding Plate Spacer	4
	SVT-E	Sliding Plate Assembly (includes items 1, 2, 3, 4, 5, 9, 10, 11)	



REAR RUBBER WHEEL FRAME ASSEMBLY

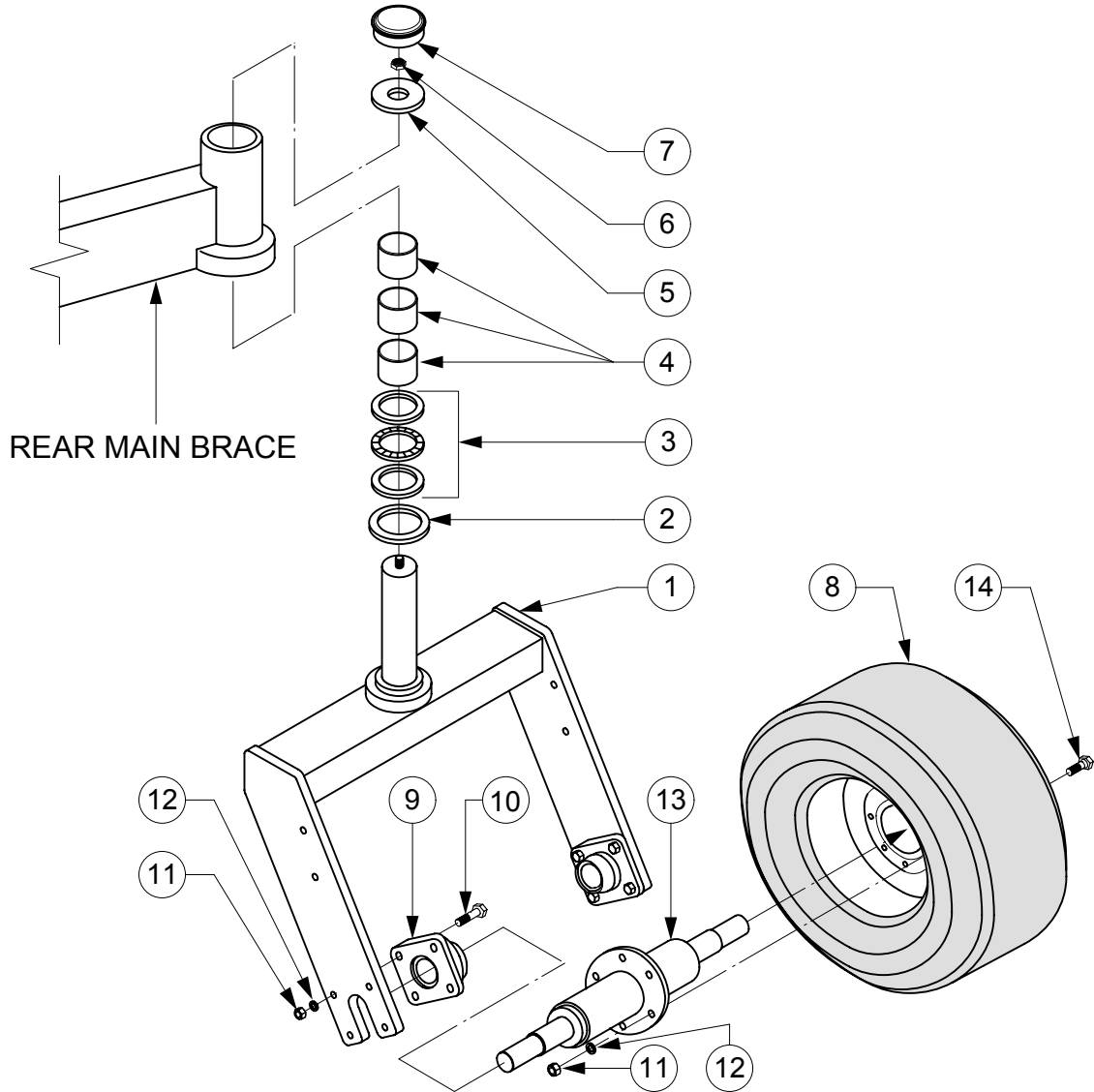

<u>Ref No.</u>	<u>Part No.</u>	<u>Description</u>	<u>Qty.</u>
1.	SVT-00G000	Rear Wheel Frame Weldment	2
2.	GBR-47394S	Grease Seal	2
3.	GBR-48TB01	3" Thrust Bearing Assembly	2
4.	GBR-4856GB	3" X 3-1/2" Garmax Bushings	6
5.	SLP-00A603	Shaft Cap	2
6.	NYNUT-14NFJ	7/8" NC Nylon Lock Jam Nut	2
7.	GBR-00GC01	Grease Cap	2
8.	GWT-111408	11 X 14 Tire with Wheel	2
9.	TPP3152	1-11/16" Flange Bearing	4
10.	CSNC508036	1/2" X 2-1/4" Gr.5 NC Cap Screw	16
11.	HXNUT-08NC	1/2" NC Hex Nut	16
12.	LWASHER-08	1/2" Lock Washer	16
13.	SVT-00H000	Varitrak Tire Mount Weldment	2
14.	WHB-08X016	1/2" X 1" Wheel Bolt	12



REAR STEEL WHEEL FRAME ASSEMBLY

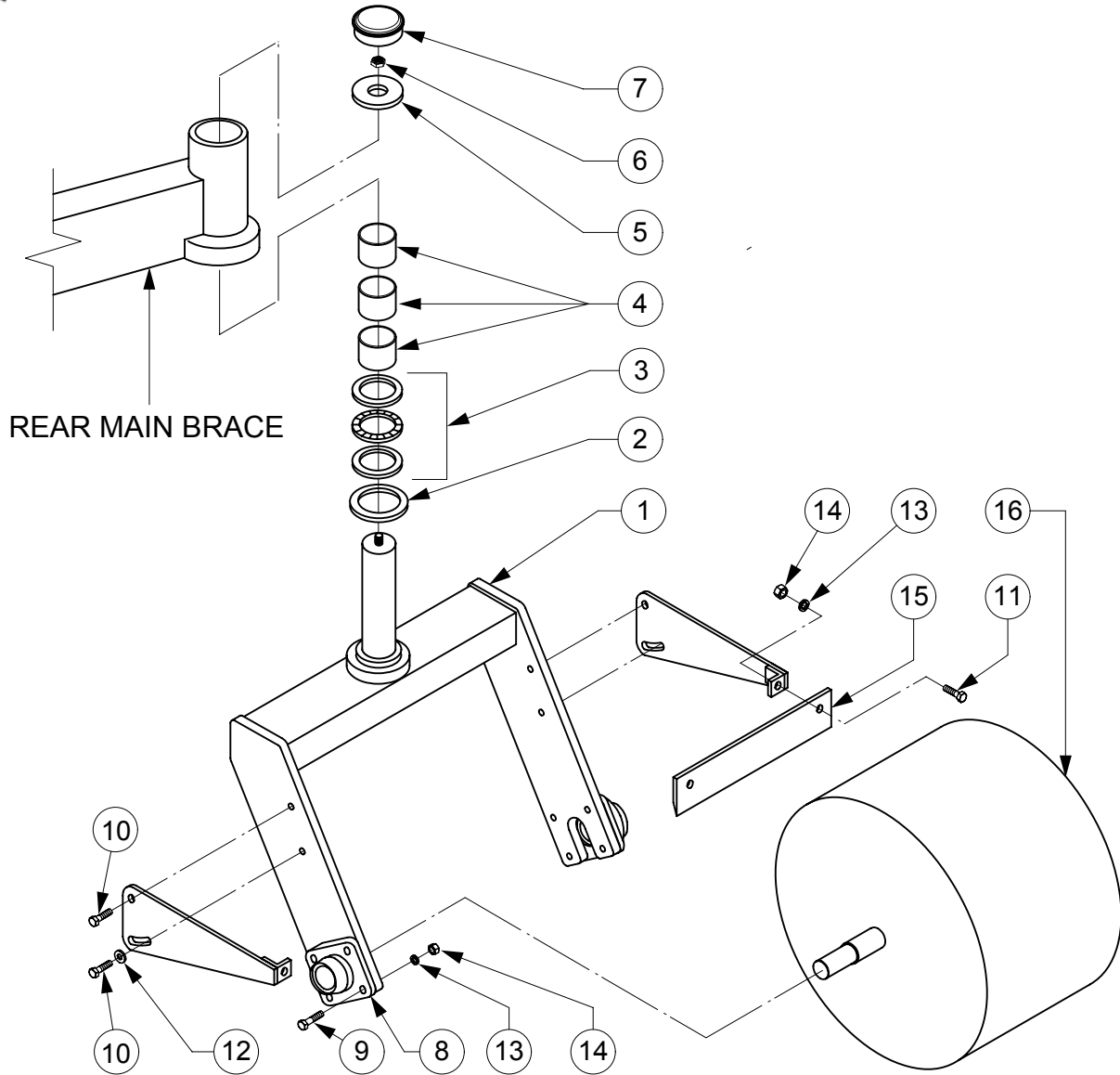

Ref No.	Part No.	Description	Qty.
1.	SVT-00G000	Rear Wheel Frame Weldment	2
2.	GBR-47394S	Grease Seal	2
3.	GBR-48TB01	3" Thrust Bearing Assembly	2
4.	GBR-4856GB	3" X 3-1/2" Self-Lubricating Bushings	6
5.	SLP-00A603	Shaft Cap	2
6.	NYNUT-14NFJ	7/8" NF Nylon Lock Jam Nut	2
7.	GBR-00GC01	Grease Cap	2
8.	TPP3152	1-11/16" Flange Bearing Complete	4
9.	CSNC508036	1/2" X 2-1/4" NC Gr.5 Cap Screw	8
10.	CSNC508032	1/2" X 2" NC Gr.5 Cap Screw	8
11.	CSNC508024	1/2" X 1-1/2" NC Gr.5 Cap Screw	4
12.	FWASHER-08	1/2" Flat Washer	4
13.	LWASHER-08	1/2" Lock Washer	20
14.	HXNUT-08NC	1/2" NC Hex Nut	20
15.	SLP-00B203	Rear Wheel Scraper Blade	2
16.	SLP-00D000	Steel Wheel Weldment	2

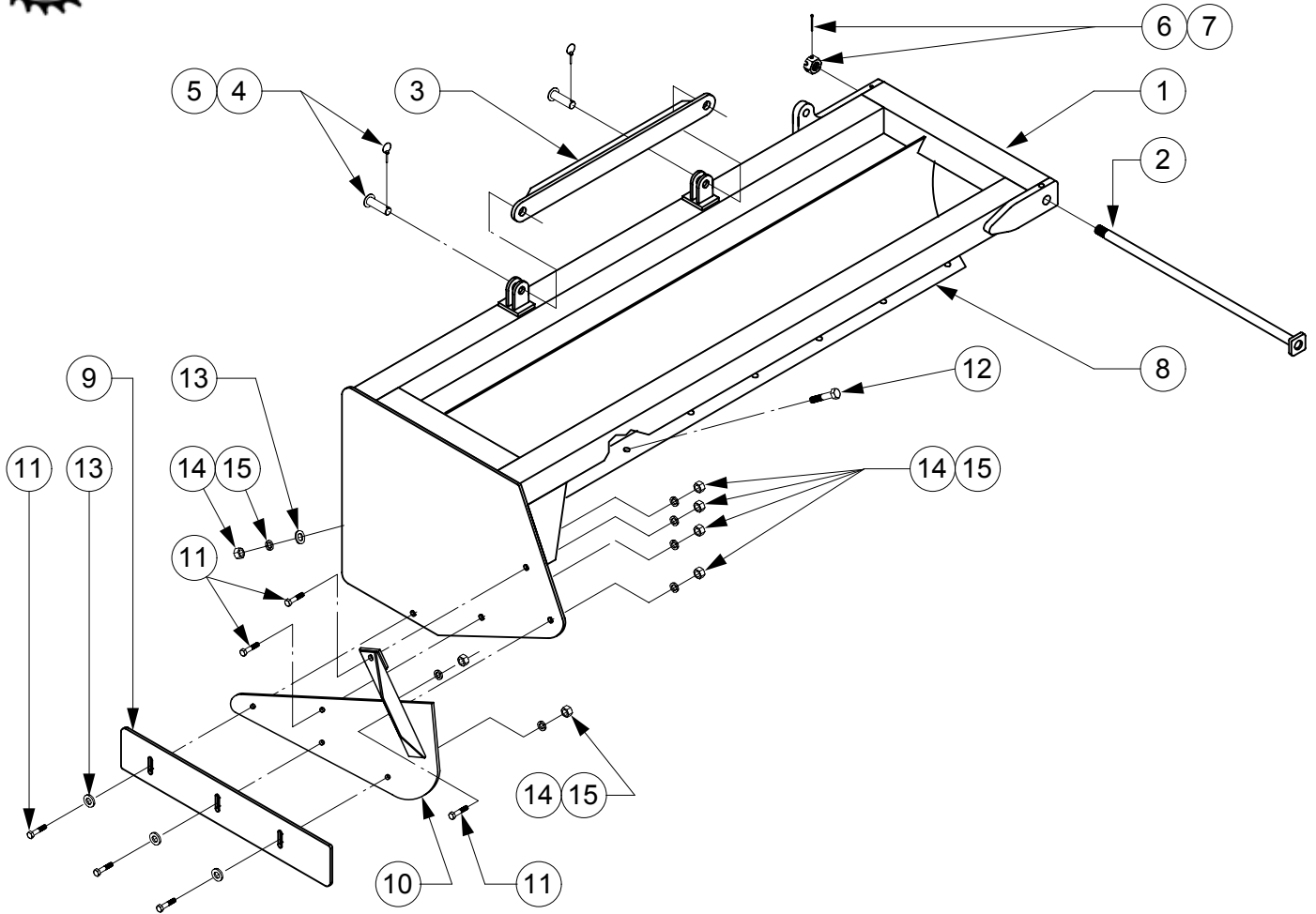

<u>Ref No.</u>	<u>Part No.</u>	<u>Description</u>	<u>Qty. per pair</u>
1.	SVT-08D100	Varitrak 8ft. Wings Weldment (pair)	1
2.	SVT-00J100	Varitrak Wing Hinge Pin Weldment	2
3.	SVT-00D200	Varitrak Lockout Weldment	2
4.	GPN-16X040	1" X 2-1/2" General Clevis Pin	4
5.	GPN-040LYN	1/4" Lynch Pin	4
6.	HXNUTS20NF	1-1/4" NF Hex Slotted Hex Nut	8
7.	GPN-04X40C	1/4" Cotter Pin	8
8.	SVT-08B205L(R)	Varitrak 8ft. Wing Blade LH and RH	2
9.	SLP-00L204	Bucket Side Adjustment Blade	2
10.	SLP-00L200L(R)	Bucket Side Weldment LH and RH	2
11.	CSNC5010032	5/8" x 2" Gr. 5 NC Cap Screw	12
12.	PBNC-10028	5/8" x 1-3/4" NC Plow Bolt	18
13.	FWASHER-10	5/8" Flat Washer	24
14.	HXNUT-10NC	5/8" NC Hex Nut	30
15.	LWASHER-10	5/8" Lock Washer	30

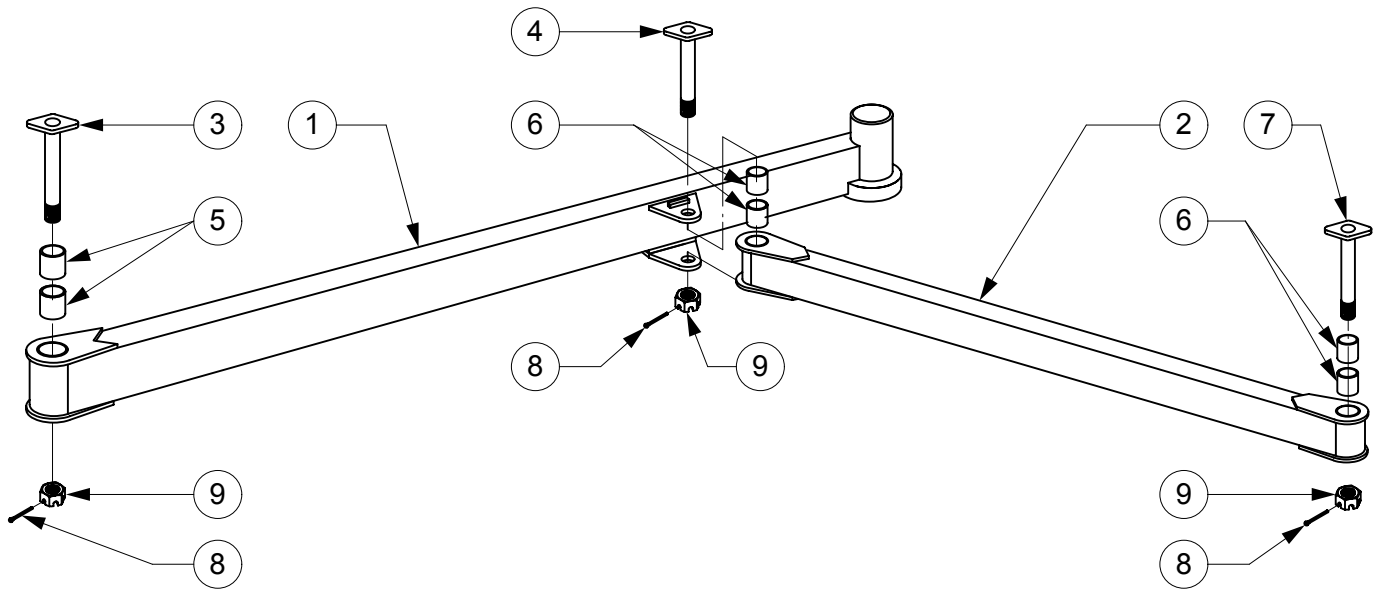

<u>Ref No.</u>	<u>Part No.</u>	<u>Description</u>	<u>Qty.</u>
1.	SVT-00C100	Varitrak Primary Brace Weldment	2
2.	SVT-00C200	Varitrak Secondary Brace Weldment	2
3.	SVT-00J400	1-1/4" x 11" Brace to Main Frame Pin Weldment	2
4.	SVT-00J200	1-1/4" x 8-1/2" Brace to Brace Pin Weldment	2
5.	GBR-2024G64	1-1/4" x 1-1/2" X 4" Self-Lubricating Bushings	4
6.	GBR-2024G48	1-1/4" x 1-1/2" X 3" Self-Lubricating Bushings	8
7.	SVT-00J300	1-1/4" x 8-3/4" Brace to Sliding Plate Pin Weldment	2
8.	GPN-04X40C	1/4" Cotter Pin	8
9.	HXNUTS20NF	1-1/4" NF Slotted Hex Nut	8

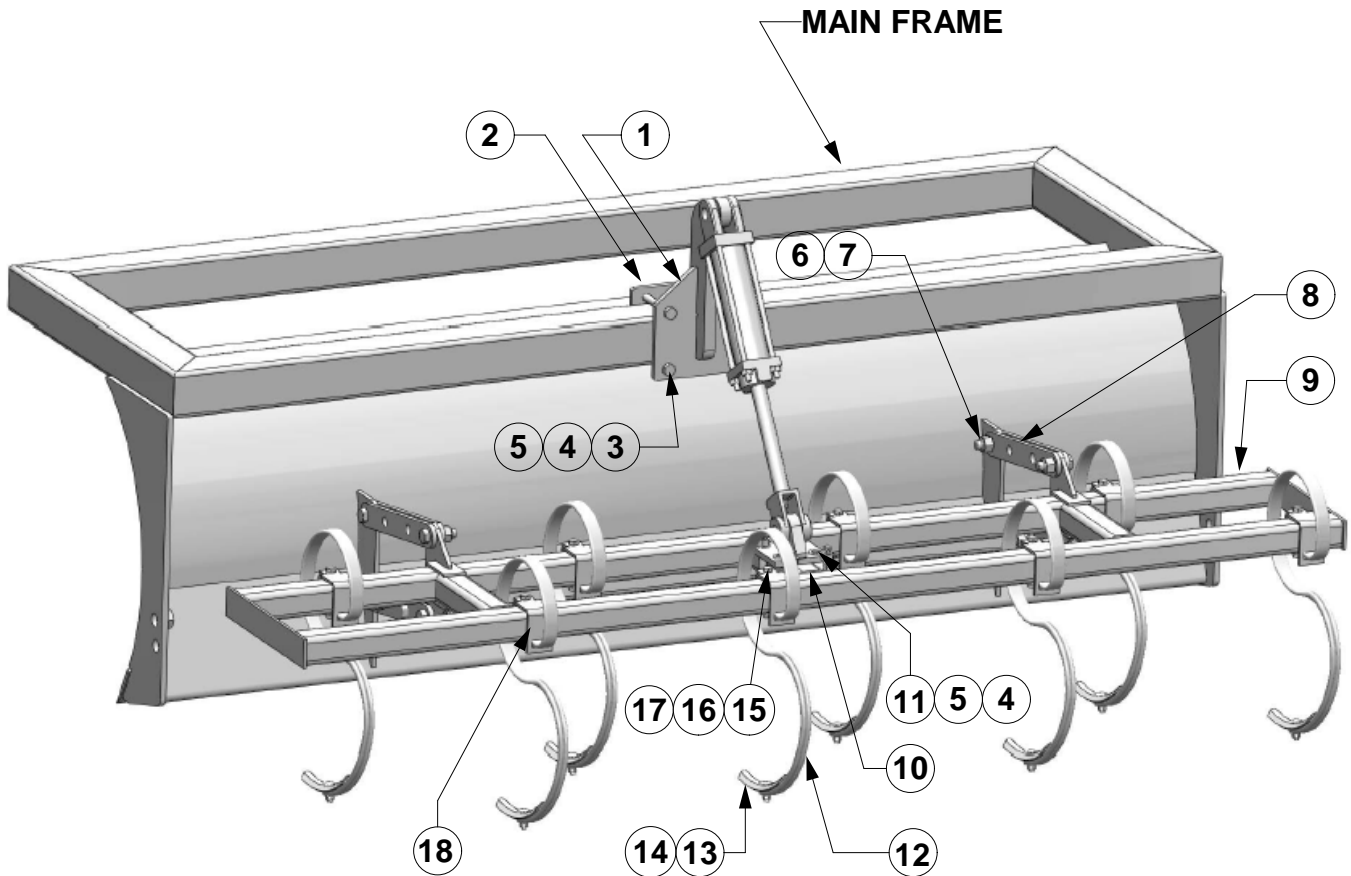

<u>Ref No.</u>	<u>Part No.</u>	<u>Description</u>	<u>Qty./Bucket</u>
1.	SVT-00L500	Cylinder Anchor Large Weldment	1
2.	SVT-00L503	Cylinder Anchor Clamp Plate	1
3.	CSNC510096	5/8" X 6" NC Gr.5 Cap Screw	4
4.	LWASHER-10	5/8" Lock Washer	8
5.	HXNUT-10NC	5/8" NC Hex Nut	8
6.	CSNC512040	3/4" X 2-1/2" NC Gr.5 Cap Screw	8
7.	NYNUT-12NC	3/4" NC Nylon Lock Nut	8
8.	SVT-00L400	S-Tine Attachment Link	8
9.	SVT-(00)L200	S-Tine Attachment Frame (specify size)	1
10.	SVT-00L100	Cylinder Anchor Small Weldment	1
11.	UBNC10X41S	5/8" NC Square U-Bolt	2
12.	GST-50125S	1/2" X 1-1/4" S-Tine Standard	varies
13.	GST-25150P	1/4" S-Tine Point	varies
14.	GST-0624BN	3/8" X 1-1/2" E-Head Bolt with Nut	varies
15.	CBNC508064	1/2" X 4" Round Head Square Neck Bolt	varies
16.	LWASHER-08	1/2" Lock Washer	varies
17.	HXNUT-08NC	1/2" NC Hex Nut	varies
18.	GST-2CL250	2-1/2" S-Tine Bar Clamp	varies



REAR

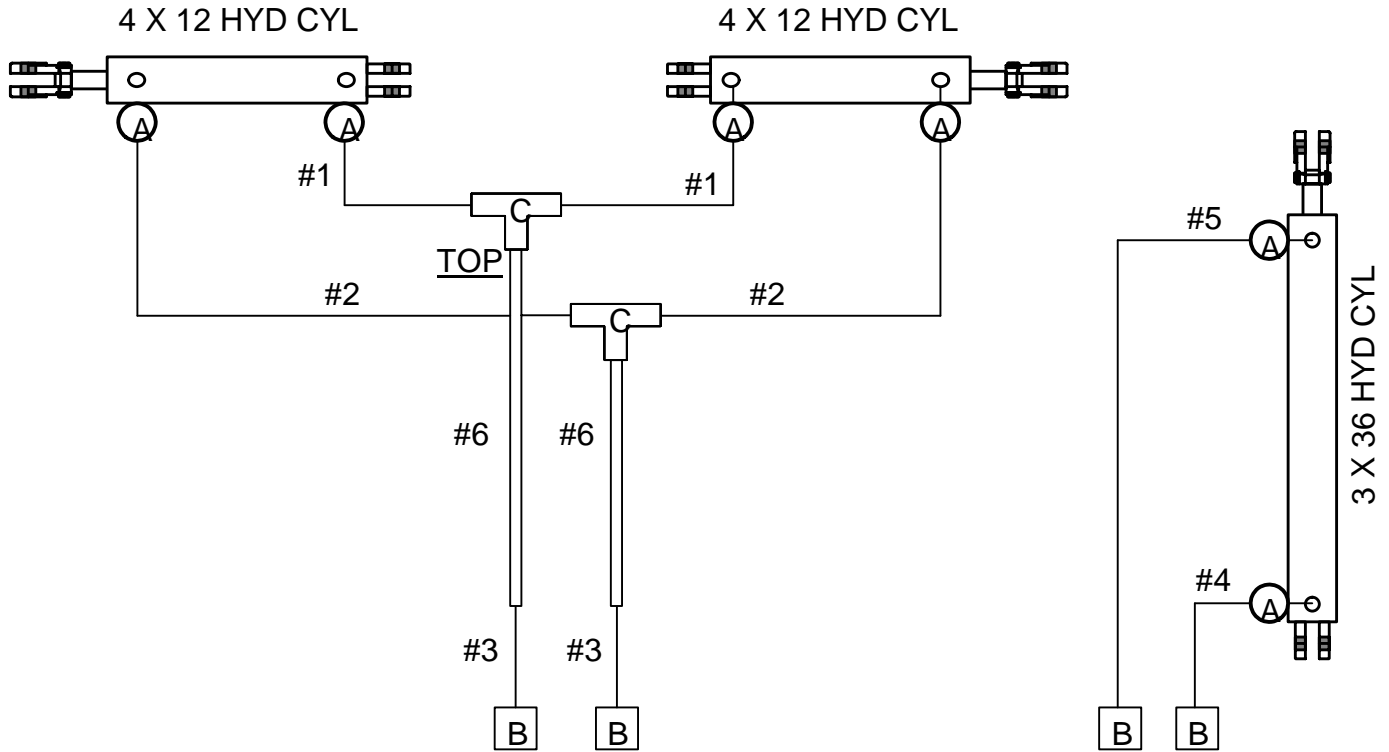

FRONT

FRONT

<u>Ref No.</u>	<u>Part No.</u>	<u>Description</u>	<u>Qty.</u>
1.	-----	8MP-8MP Hydraulic Hose 24" Long	2
2.	-----	8MP-8MP Hydraulic Hose 30" Long	2
3.	-----	8MP-8MP Hydraulic Hose 80" Long	2
4.	-----	8MP-8MP Hydraulic Hose 104" Long	1
5.	-----	8MP-8MP Hydraulic Hose 140" Long	1
	HKSVT	Varitrak Hose Kit (includes items 1 through 5)	1
6.	TB4-00A303	Hydraulic Line 54" Long	2
A	FMBFPX9088	1/2" MB-1/2" FP Swivel 90 Fitting	6
B	FFP08000PT	1/2" FP Pioneer Tip	4
C	FFPT080000	1/2" FP "T" Fitting	2
	GHC-40120T	4" X 12" Tie Rod Hydraulic Cylinder	2
	GHC-30360T	3" X 36" Tie Rod Hydraulic Cylinder	1



REAR RH WING

2-1/2" X 8" HYD CYL

REAR MF

2-3/4" X 8" HYD CYL

REAR LH WING

3" X 8" HYD CYL

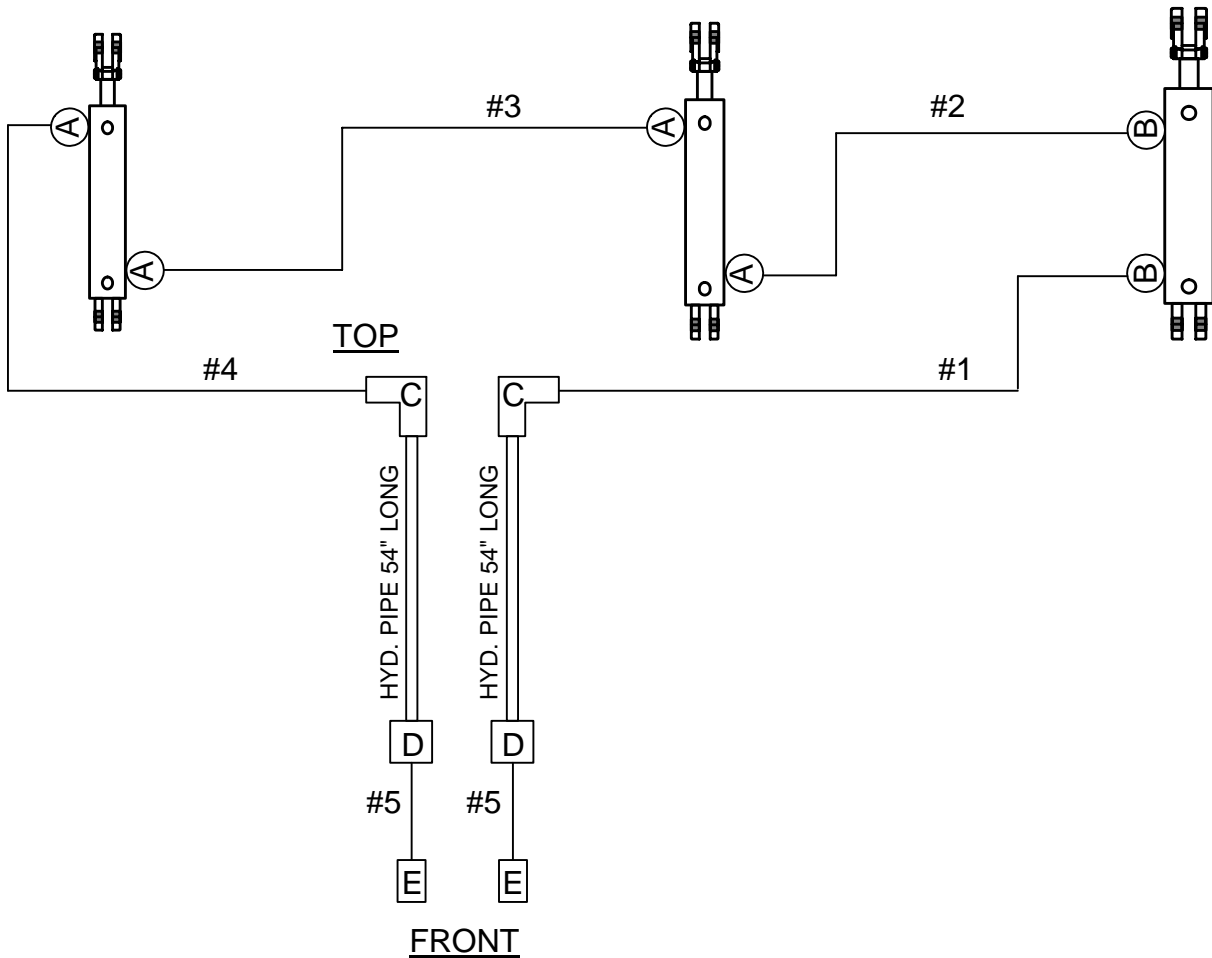

<u>Ref No.</u>	<u>Part No.</u>	<u>Description</u>	<u>Qty.</u>
1.	-----	8MP-8MP 108" long	1
2.	-----	8MP-8MP 143" long	1
3.	-----	8MP-8MP 94" long	1
4.	-----	8MP-8MP 120" long	1
5.	-----	8MP-8MP 80" long	2
	TB4-00A303	Hydraulic Pipe 54" Long	2
A	FMBFPX9088	1/2" MB-1/2" FP Swivel 90 Fitting	4
B	FMBFP88C	1/2" MB-FP Coupling Straight	2
C	FFPFP9088C	1/2" FP-FP Elbow Fitting	2
D	FFPFP8800C	1/2" FP-FP Coupling	2
E	FFP08000PT	1/2" FP Pioneer Tip	2
	GHC-3008MS	3" X 8" Series Tie Rod Hydraulic Cylinder	1
	GHC-2758MS	2-3/4" X 8" Series Tie Rod Hydraulic Cylinder	1
	GHC-2508MS	2-1/2" X 8" Series Tie Rod Hydraulic Cylinder	1

T.G. SCHMEISER CO., INC.®

Limited Warranty Statement

T. G. Schmeiser Co., Inc. warrants each new Schmeiser® product to be free from defects in material and workmanship. This warranty is applicable only for the normal service life expectancy of the product or components, not to exceed twelve (12) consecutive months from the date of delivery of the new Schmeiser product to the original purchaser.

Genuine T. G. Schmeiser Co., Inc. replacement parts and components will be warranted for 90 days from date of purchase, or the remainder of the original equipment warranty period, whichever is longer.

Under no circumstances will it cover any merchandise or components thereof, which, in the opinion of the company, has been subjected to misuse, unauthorized modifications, alteration, an accident or if repairs have been made with parts other than those obtainable through T. G. Schmeiser Co., Inc.

The Company in no way warrants engines, batteries, cylinders, tires or other trade accessories since these items are warranted separately by their respective manufacturer. Expendable components such as points, shanks, blades, rings, bearings, teeth, and the like are excluded from this warranty.

Our obligation under this warranty shall be limited to repairing or replacing, free of charge to the original purchaser, any part that, in our judgment, shall show evidence of such defect, provided further that such part shall be returned within thirty (30) days from date of failure to T. G. Schmeiser Co., Inc., routed through the dealer and distributor from whom the purchase was made, transportation charges prepaid.

This warranty shall not be interpreted to render T. G. Schmeiser Co., Inc. liable for injury or damages of any kind or nature to person or property. This warranty does not extend to the loss of crops, loss because of delay in harvesting, or any expense or loss incurred for labor, substitute machinery, rental or for any other reason.

Except as set forth above, **T. G. Schmeiser Co., Inc. shall have no obligation or liability of any kind on account of any of its equipment and shall not be liable for special or consequential damages. T. G. Schmeiser Co., Inc. makes no other warranty, expressed or implied, and, specifically, T. G. Schmeiser Co., Inc. disclaims any implied warranty or merchantability or fitness for a particular purpose. Some states or provinces do not permit limitations or exclusions of implied warranties or incidental or consequential damages, so the limitations or exclusion in this warranty may not apply.**

This warranty is subject to any existing conditions of supply, which may directly affect our ability to obtain materials or manufacture replacement parts.

T. G. Schmeiser Co., Inc. reserves the right to make improvements in design or changes in specifications at any time, without incurring any obligation to owners of units previously sold.

No one is authorized to alter, modify or enlarge this warranty nor the exclusion, limitations and reservations.

**WARRANTY VOID IF NOT REGISTERED
WITHIN 30 DAYS OF PURCHASE DATE**

